

1859-12434A-00-xx_R00

| ITEM | QTY. | DESCRIPTION | PART NUMBER | MATERIAL |
|------|------|------------------------|-------------------|----------|
| 1 | 1 | VST-50 I.G. @ 1.9 S.G. | 1039-02434T-00-xx | PE |
| 2 | 1 | 6" SCREW CAP | 9707-016000-80-10 | 10 HDPE |
| 3 | 1 | 6" SCREW CAP GASKET | 9707-056000-00-65 | 65 EPDM |
| 4 | 1 | 1.0" [25 MM] FNPT BOSS | 9701-011000-00-00 | 00 MDPE |

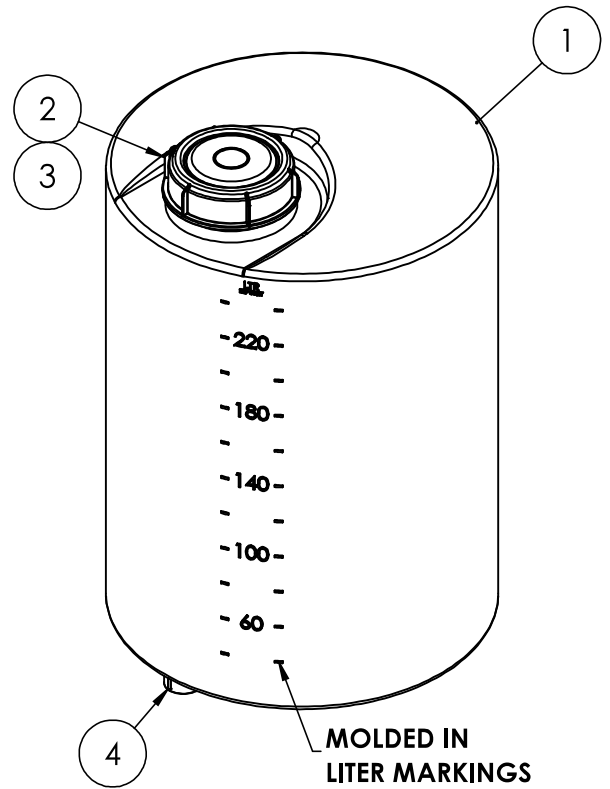
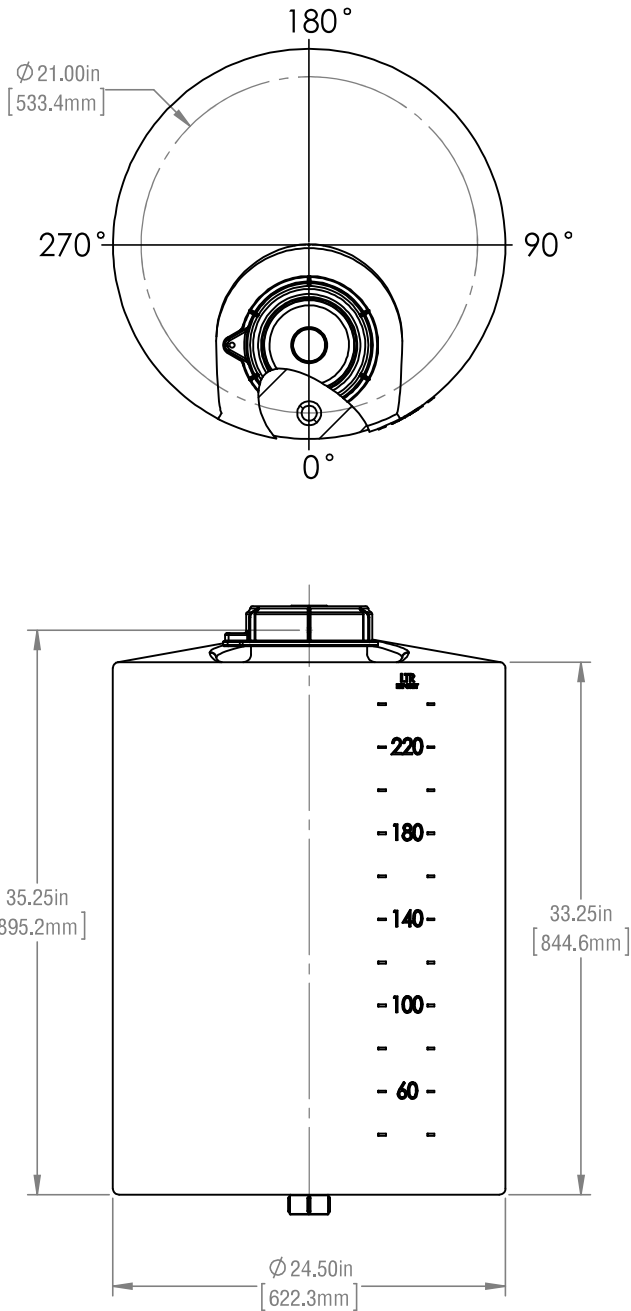

- NOTES:
 1) REFER TO PLAN VIEW FOR FITTING ORIENTATION
 2) ALL TRIMMED EDGES ARE ROUNDED OFF
 3) ALL DIMENSIONS ARE APPROXIMATE
 4) CAPACITY 50 IG (60 USG/240 L)

FAILURE TO PROVIDE ADEQUATE PROVISIONS FOR TANK EXPANSION/CONTRACTION AT FITTINGS WILL VOID ALL WARRANTIES.

****TANK AVAILABLE IN 00 MDPE OR 10 HDPE****

| REVISIONS | | |
|-----------|---------------------|------------|
| REV. | DESCRIPTION | DATE |
| 00 | KP - CREATED LAYOUT | 2016-03-17 |

FINAL APPROVED DRAWING CUSTOMER:..... DATE:.....